



**天津市博雷阀门有限公司**  
TIANJIN BOLLEY VALVE CO. LTD.

AW SERIES PNEUMATIC  
ACTUATORS

AW 系列气动执行器



**建百年博雷阀门 创国际品牌**

BUILT IN ONE HUNDRED BOLLEY VALVE  
THE FAR EAST AND INTERNATIONAL BRAND



# COMPANY PROFILE

## 公司简介

天津市博雷阀门有限公司是一家集开发、生产、销售于一体的阀门公司，具有多年专业设计制造阀门丰富经验，技术力量雄厚，生产工艺先进，拥有现代化机械加工中心和检测设备。

公司主导产品有：闸阀、截止阀、蝶阀、球阀、止回阀、调节阀、减压阀、隔膜阀、旋塞阀、柱塞阀、疏水阀、安全阀、美标阀、水力控制阀等80多种品种、300多个系列、几千种规格。产品采用GB、JB、HG、API、ANSI、DIN、JIS、BS等国内外先进标准设计制造。通径从1/4"至96"(DN6-2400 mm)、压力从150LB至2500LB (2MPa-42MPa)、工作温度为-196℃至800℃。主要材质有灰铸铁、球墨铸铁、铜、碳素钢、不锈钢、合金钢、低温钢、铬钼钢、沉淀硬化钢及其他特殊钢材。阀门驱动方式有：手动、齿轮传动、电动、气动和液动；连接方式有：焊接、法兰、螺纹、对夹、卡套等系列产品。

多年来，公司产品广泛应用于电力、石油、化工、冶金、造纸、蒸汽、制药、燃气、环保、染料、供热、城建、污水处理等行业，产品已在全国各地享有盛誉，并远销东南亚国家和地区，深受广大客户好评。

Tianjin Bolley Valve Co., Ltd. is a collection development, production and sales of integrated valve company, has many years of professional design and manufacture of valves, rich experience, strong technical force, advanced production technology, with modern machining centers and testing equipment.

Our main products are: Gate Valve, Globe Valve, Butterfly Valve, Ball Valve, Check Valve, Control Valve, Relief Valve, Diaphragm Valve, Plug Valve, Plunger Valve, Drain Valve, Safety Valve, American Standard Valves, Hydraulic Control Valves and other 80 kinds of varieties, more than 300 series, thousands of specifications. The products are designed and manufactured by GB, JB, HG, API, ANSI, DIN, JIS, BS and other advanced standards at home and abroad. The diameter is from 1/4 "to 96" (DN6-2400mm), the pressure is from 150LB to 2500LB (2MPa-42MPa), and the working temperature is from -196℃ to 800℃. The main materials are cast iron, ductile iron, copper, carbon steel, stainless steel, alloy steel, low temperature steel, chrome molybdenum steel, precipitation hardening steel and other special steel. The valve drive methods are: manual, gear drive, electric, pneumatic and hydraulic; connection methods are: welding, flange, thread, pairs of clamps, clamps and other products.

Over the years, the company's products are widely used in electric power, petroleum, chemical industry, metallurgy, papermaking, steam, gas, pharmaceutical, environmental protection, dyes, heating, urban construction, sewage treatment and other industries, products have been renowned throughout the country and exported to Southeast Asian countries and regions, well received by our customers.

**我们力求每一个环节都做到精益求精，  
争做控制系统行业之美好明天的领航者！**

We Strive To Achieve Excellence In Every Aspect,  
To Control System Of Industry Leader A Better Tomorrow!



### W系列气动执行器特点

AW系列气动执行器分为双作用和单作用式(弹簧复位), 两个分体气缸, 输出扭矩大, 动作灵活平衡; 活塞杆镀硬铬, 有很好的抗磨性; 所有滑动部件之间配有无油润滑轴和导向环以降低摩擦系数, 延长使用寿命AW气动执行器的U型曲线特性输出扭矩更适用于大口径球、蝶阀等转角行程阀门的启、闭和调节, 也可用于其它回转运动的场合, 是实现工业管道自动化控制的理想装置。

### AW Series Pneumatic Actuator

AW Series pneumatic actuators are divided into double-acting and single acting (spring reset), two divided cylinder, large output torque, flexible motion balance; The piston rod, hard chromium plating has good wear resistance; All sliding parts with oil free lubrication between shaft and guide ring to reduce friction coefficient, prolong the service life of u-shaped curve characteristics of AW pneumatic actuator output torque is more suitable for large diameter ball, butterfly and so on Angle of stroke the valve opening and closing and adjustment, can also be used to other rotary movement of the occasion, is the ideal device to realize pipeline automation control.

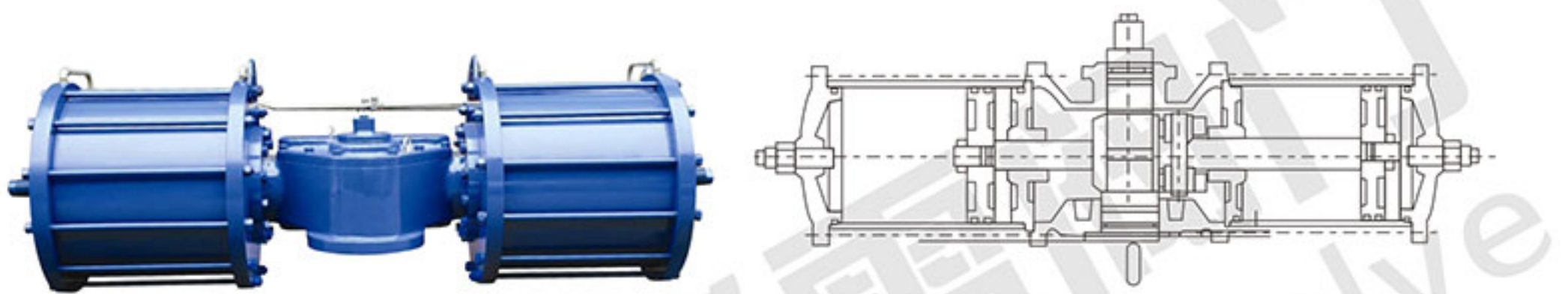

### AW系列气动执行器输出扭矩表 AW Series Pneumatic Actuator Output Torque Meter

Aw双作用型输出扭矩表 AW Double-acting type output torque meter					AWS单作用型输出扭矩表 AWS Single acting type output torque meter								
型号 Model	输出扭矩 Output torque (N.m)				型号 Model	弹簧扭矩 Torque of the spring (N.m)		输出扭矩 Output torque (N.m)					
	0.4MPa	0.5MPa	0.6MPa	0.7MPa		最大 Biggest	最大 Biggest	0.4MPa		0.5MPa		0.6MPa	
								最大 Biggest	最大 Biggest	最大 Biggest	最大 Biggest	最大 Biggest	最大 Biggest
AW13	620	770	930	1080	AWS13	230	430	183	330	330	540	490	700
AW17	1270	1590	1910	2230	AWS17	330	670	600	930	920	1290	1230	1573
AW20	2430	3040	3650	4260	AWS20	1010	1430	700	1120	1230	1650	1770	2190
AW22	3470	4330	5200	6070	AWS22	1180	1700	980	1480	1700	2540	2420	3300
AW25	4810	6010	7220	8430	AWS25	1570	2890	1890	3230	3160	4560	4330	5440
AW28	6860	8580	10300	12020	AWS28	2900	5610	1250	3960	2970	5685	4680	7400
AW35	13500	16870	20250	23620	AWS35	5520	10740	2760	7970	6130	11340	9510	14720
AW40	17630	22040	26450	30860	AWS40	8770	16140	4480	8860	6900	13260	10300	17690

### 气缸容积及重量和耗气量计算 Cylinder Volume And Weight And Calculate Gas Consumption

型号规格 Model specification		AW13	AW17	AW20	AW28	AW35	AW40
气缸容量L Cylinder size L	双作用式 Double acting type	6.3	14.3	30.8	73	148	193
	单作用式 Single acting	3.25	7.15	15.4	36.5	74	96.5
重量 Weight (Kg)	双作用式 Double acting type	45	79	168	320	600	780
	单作用式 Single acting	62	112	219	445	835	1050



### ■ 型号编制 Model Establishment

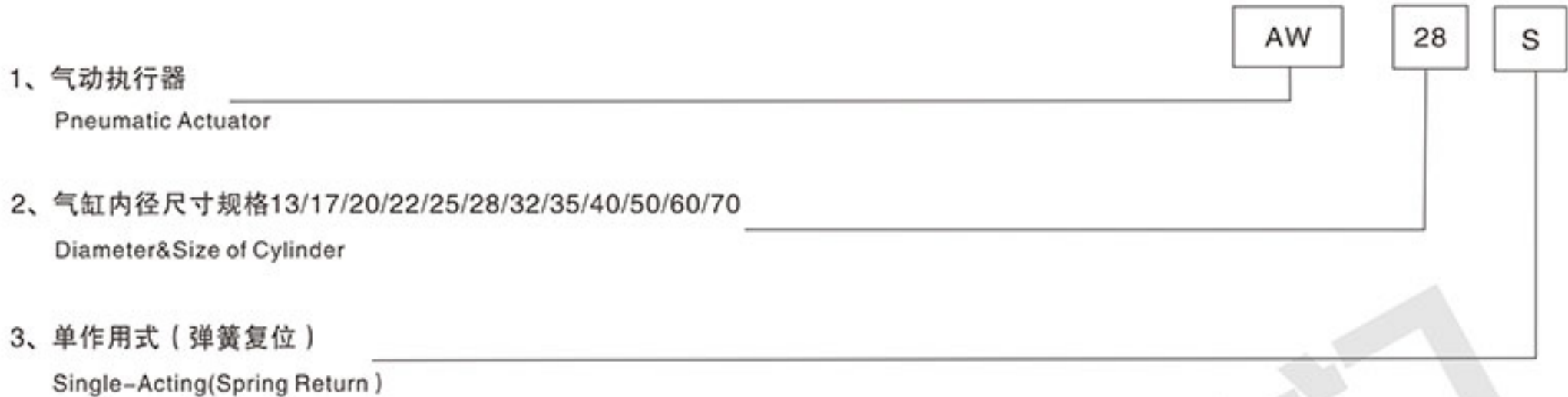

### ■ 执行器选用与安装 Actuator Selection & Installation

使用AW气动执行器时，先确定阀门的扭矩，考虑管道介质；水蒸气或非润滑的介质增加25%安全值；非润滑的干气介质增加60%安全值；非润滑用气体输送的颗粒粉料介质增加100%的安全值；对于清洁、无摩擦的润滑介质增加20%安全值，然后根据气源工作压力，查找双作用式或单作用式扭矩表，可得到准确的执行器型号。

气动执行器与阀门安装精度是否正确，直接影响执行器安全操作和使用寿命。合理连接安装使执行器中心轴与阀杆同轴。执行器与阀门装配之前，应对阀门扭矩测定，不应超出所要求扭矩。装配后，气动执行器和阀门同时试验，对阀门加压到额定密封压力，执行器以气源压力为0.4~0.7MPa或按用户需要的气源压力，对气动执行器的两个进气口进行切换进气，观察气动阀门的开启和关闭情况，不应有停顿、爬行现象，应开关灵活旋转，并要进行多次反复试验。

When select the actuator, the torque of valve must be identified firstly, then consider the pipe media; Add 25% Security value when it is steam or non-lubricated media; Add 60% security value when it is non-lubricated dry gas media; Add 100% security value when it is non-lubricated gas transmission particles media; Add 20% security value when it is clean and no friction lubrication media; Then check the double-acting or single-acting type torque form according to air source pressure, and the model of actuator can be chosen correctly,

The pneumatic actuators and valve installation precision is correct, directly influence the actuator safety operation and service life, Reasonable connection installed make actuators center axis and stem coaxial, Actuators with valve assembly to determine valve torque, before, should not be beyond the required torque. After the assembly, the pneumatic actuators and valve and test, the valve pressure rated pressure to seal, actuators to air pressure is 0.4-0.7 MPA or according to the needs of user of pneumatic air pressure, the implementation of the two inlet air intake to switch, observation of the pneumatic valves open and shut case, not due pause, creep phenomenon, should be flexible rotation, and to switch to DuoCi repeated test.

### ■ 执行器及附件的功能和用途

双动式气动执行器：对阀门开启和关闭的两位式控制。

弹簧复位式：在电路气路切断或故障，阀门自动开启或关闭。

单电控电磁阀：供电时阀门打开或关闭，断电时阀门关闭或打开（可提供防爆型）。

双电控电磁阀：一个线圈得电时阀门打开，另一个线圈得电时阀门关闭，有记忆功能（可提供防爆型）。

限位开关回讯器：远距离传送阀门的开关位置的信号（可提供防爆型）。

电气定位器：根据电流信号（标准4~20mA）的大小对阀门的介质流量调节控制。

气动定位器：根据气压信号（标准0.02~0.1MPa）的大小对阀门的介质流量调节控制。

电气转换器：将电流信号成气压信号，与气动定位器配套使用（可提供防爆型）。



气源处理三联件：包括空气减压阀、过滤器、油雾器，对气原稳压、清洁、运动部件润滑作用。

手动操作机构：自动控制在不正常情况下以手动操作。

Double-acting pneumatic actuator: Double position control of valve's open or close.

Spring Return: Valve open or close automatically when circuit, gas is cut of or failure (Explosion-proof offer available).

Single-control solenoid valve: Valve opens or closes when power on, vice versa (explosion-proof offer available).

Double-control solenoid valve: Valve opens when one coil is power-on, Valve closes when another coil power-off, It has memory-save function (explosion-proof offer available).

Limit Switch Box: Long-distance transmission of valve position signal (explosion-proof offer available).

Electric Locator: Regulate and control the flow of media according to current signal (Standard 4-20mA) (explosion-proof offer available).

Pneumatic Locator: Regulate and control the flow of media according to pressure signal (Standard 0.02-0.1 MPa).

Electrical Converters: It converts current signal into pressure signal, and used with pneumatic locator (explosion-proof offer available).

Air Source Treatment Triple-Unit: It includes pressure reducer, filter, oil mist and has air pressure-stability, air source-cleaning, partslubrication functions.

Manual Operation Institutions: It can be manual operated if automatic operation is out of control.

## 定货须知 Order Notice

气动阀门是复杂的自动化控制仪表，由多种气动元件组成，用户根据控制需要，详细选择下列附件，并在技术合同上注明。

- 1、气动执行器：(1)双作用式 (2)单作用式 (3)型号规格
- 2、电磁阀：(1)单控电磁阀 (2)双控电磁阀 (3)使用电压 (4)防爆型
- 3、信号反馈：(1)机械式开关 (2)接近式开关 (3)输出电流信号 (4)使用电压 (5)防爆型
- 4、定位器：(1)电气定位器 (2)气动定位器 (3)电流信号 (4)气压信号 (5)电气转换器 (6)防爆型
- 5、气源处理三联件：(1)过滤减压阀 (2)油雾器
- 6、手动操作机构。
- 7、特殊接口尺寸。
- 8、特殊定制。

Pneumatic valve is complex intelligent-control instrument that is a combination of pneumatic components. Users must choose accessories detailed according to their requirements, and note on technology contracts.

- 1、Pneumatic Actuators: (1)Double-Acting、(2)Single-Acting、(3)Model
- 2、Solenoid Valve: (1)Single-Control Solenoid Valve、(2)Double-Control Solenoid Valve、(3)Voltage、(4)Explosion-Proof Type
- 3、Feedback Signal: (1)Mechanical Switches、(2)Approachable Switches、(3)Output Current Signal、(4)Voltage、(5)Explosion-Proof Type
- 4、Locator: (1)Electric Locator、(2)Pneumatic Locator、(3)Current Signal、(4) Air Pressure Signal、(5) Electrical Converter、(6) Explosion-Proof Type
- 5、Air Source Treatment Triple-Unit: (1)Filter & Pressure Reducer Valve、(2)Oil Mist
- 6、Manual Operation Institution
- 7、Special Interface Size
- 8、Special Order



# AW 系列气动执行器 AW SERIES PNEUMATIC ACTUATORS

## ■ 双作用式配管原理 Double-acting Type Work Theory

常闭式 ( 通电开启型 ) (open when power on)

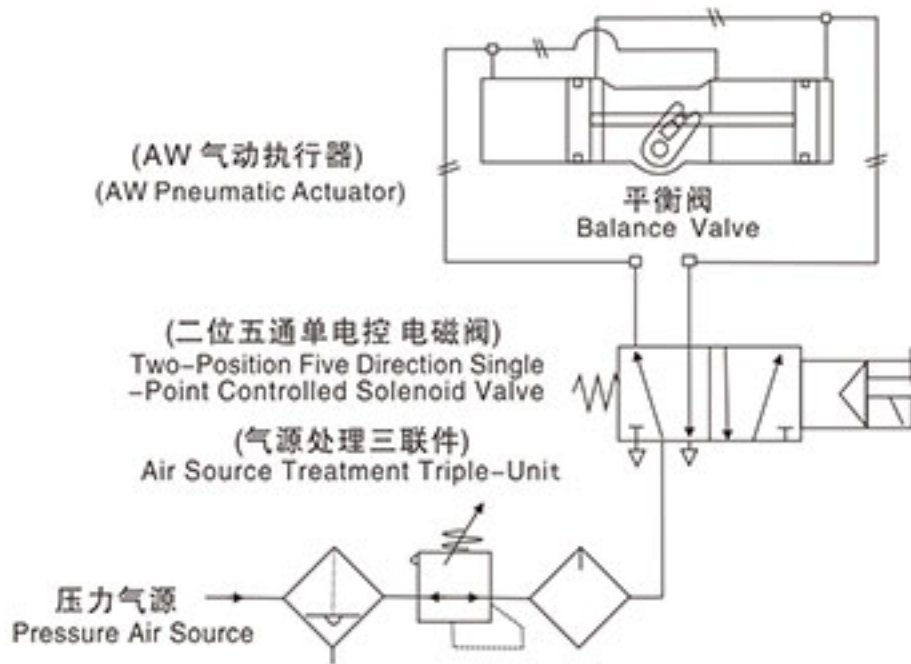

常开式 ( 通电切断型 ) (cut off when power on)

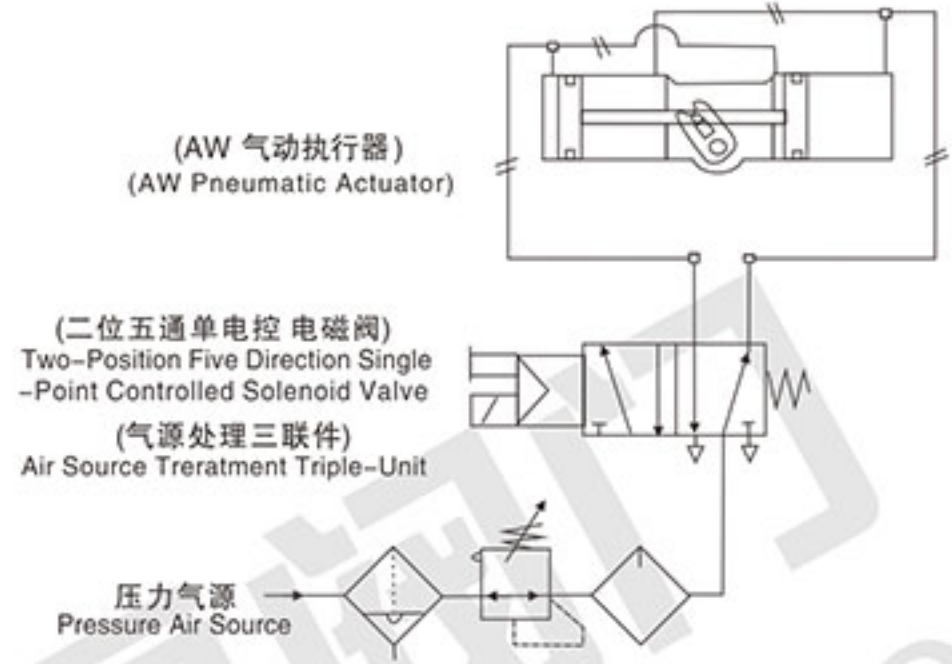

## ■ 单作用式配管原理 Single-acting Type Work Theory

常闭式 ( 通电开启型 ) (open when power on)

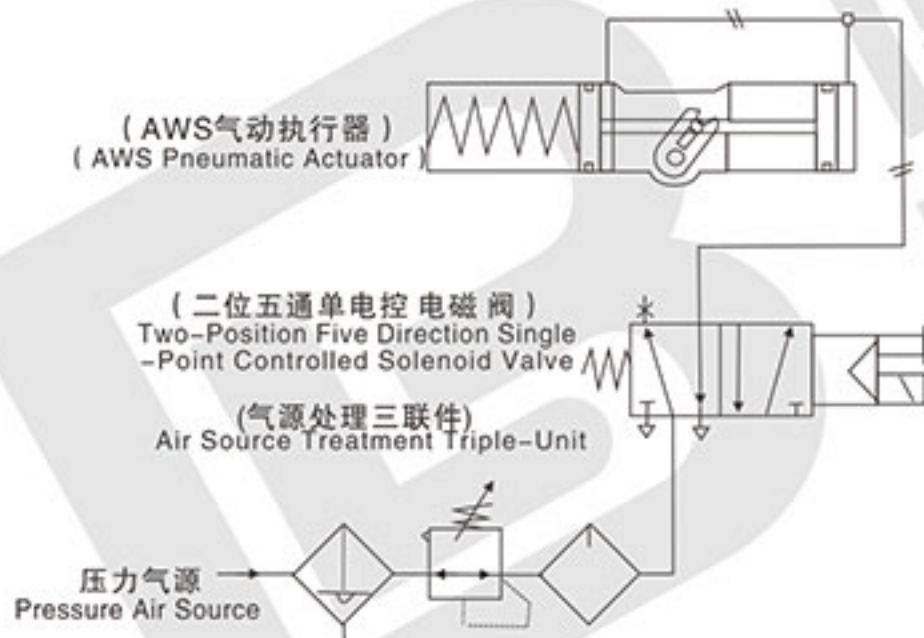

常开式 ( 通电切断型 ) (cut off when power on)

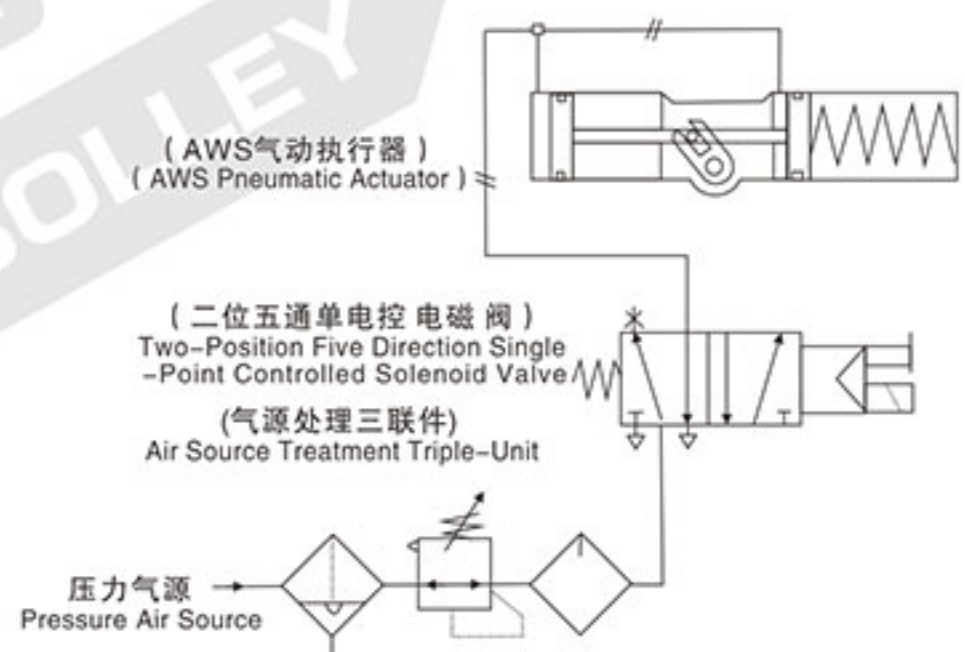

## ■ 调节式配管原理 ( 配电气定位器 ) Adjusting Type Work Theory (With Electric Locator)

双作用式 Double-Acting Type

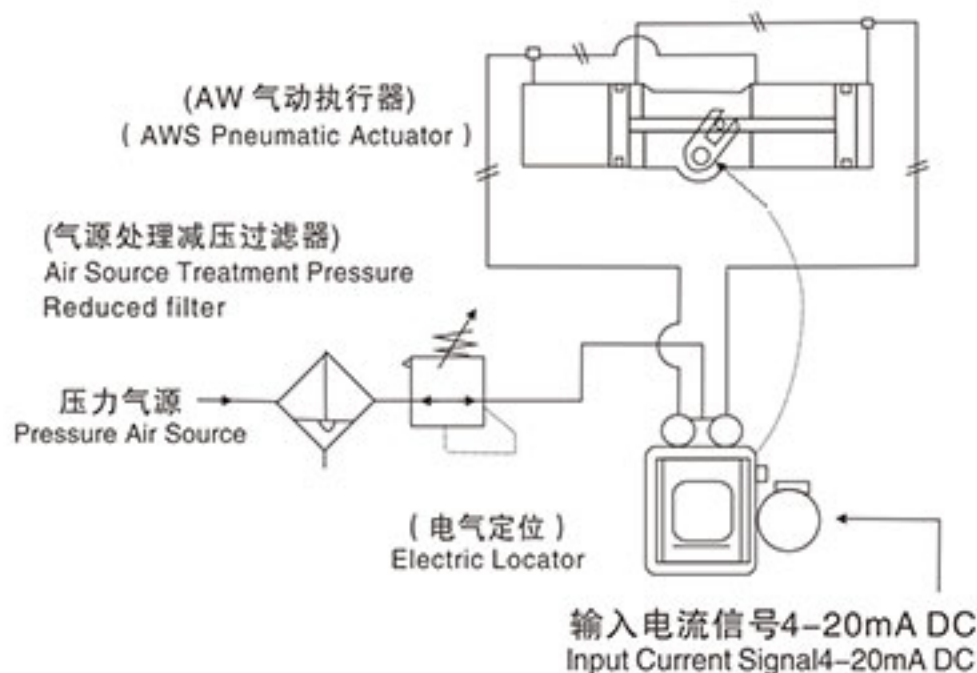

单作用式 Single-Acting Type

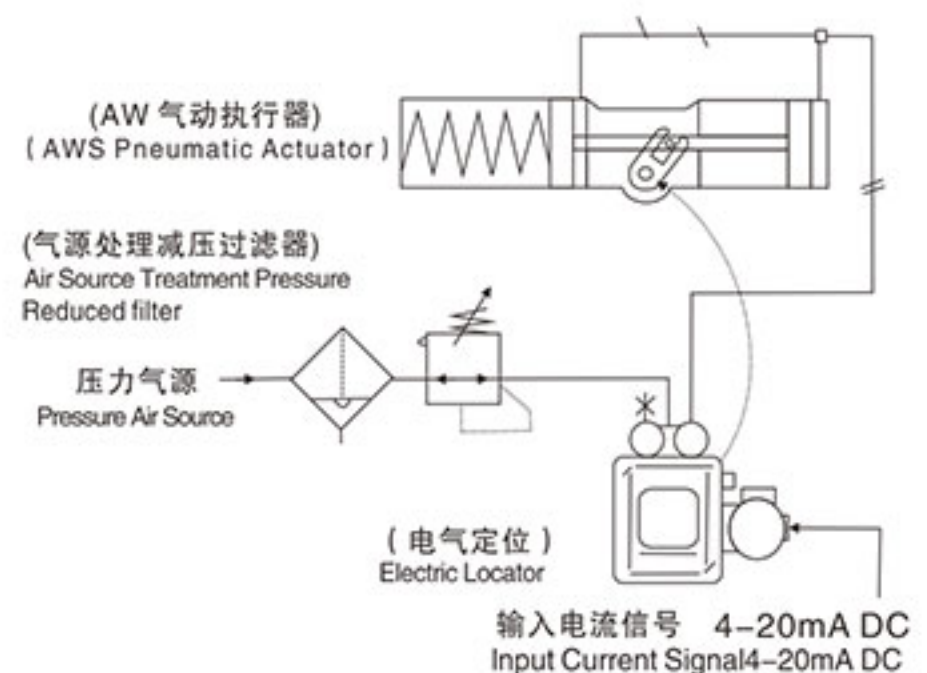



■ 双作用式输出扭矩 Double-Acting Type Output Torque

单位 Unit: N.m

型号规格 Model	气源压力 Air Source Pressure (MPa)				
	0.3	0.4	0.5	0.6	0.7
AW13	515	620	770	930	1080
AW17	950	1270	1590	1910	2230
AW20	1820	2430	3040	3650	4260
AW22	2600	3470	4330	5200	6070
AW25	3360	4480	5600	6720	7850
AW28	5150	6860	8580	10300	12020
AW32	7620	10150	12680	15220	17760
AW35	10120	13500	16870	20250	23620
AW40	13220	17630	22040	26450	30860
AW50	22400	29900	37400	44900	52400
AW60	47300	63070	78840	94610	110380
AW70	67440	89930	112400	134800	157300

■ 单作用式输出扭矩 Single-Acting Type Output Torque

单位 Unit: N.m

型号规格 Model	弹簧扭矩 Spring Torque		气源压力 Air Source Pressure (MPa)					
			0.4MPa		0.5MPa		0.6MPa	
	最小Min	最大Max	最小Min	最大Max	最小Min	最大Max	最小Min	最大Max
AW13S	230	430	185	340	340	545	490	700
AW17S	330	670	600	930	920	1290	1230	1573
AW20S	1010	1430	700	1120	1230	1650	1770	2190
AW22S	1280	2190	1190	2030	1950	2860	2820	3730
AW25S	1960	3070	1410	2520	2530	3640	3650	4760
AW28S	2900	5610	1250	3960	2970	5685	4680	7400
AW32S	4250	8250	1900	5900	4430	8430	6970	10970
AW35S	5520	10740	2760	7970	6130	11340	9510	14720
AW40S	8770	16140	4480	8860	6900	13260	10300	17670
AW50S	13000	27000	6300	20200	14300	29000	23000	37000

■ 气缸容积和重量 Cylinder Volume & Weight

型号规格 Model	AW13	AW17	AW20	AW22	AW25	AW28	AW32	AW35	AW40	AW50	AW50		
(升)气缸容量L Cylinder volume(L)	3.25	7.5	13.1	15.4	24.2	36.5	50.7	74.1	96.1	175	315		
重量Kg (公斤) Weight(Kg)	双作用 Double-Acting		48	82	150	170	215	325	460	600	800	1070	1580
	单作用 Single-Acting		65	116	203	223	312	462	720	845	1070	1400	



# AW 系列气动执行器

## AW SERIES PNEUMATIC ACTUATORS

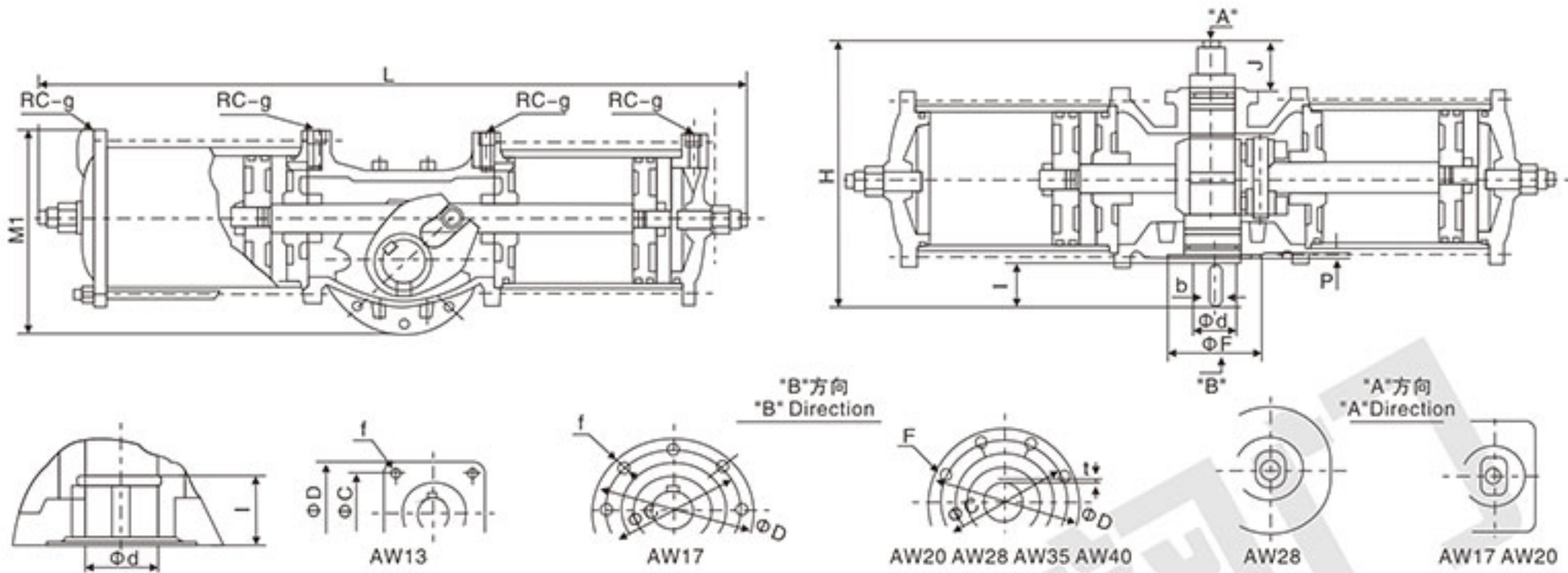

### 双作用式外形尺寸 Double-acting Shape size

型号 Model	L	M1	H	$\phi C$	$\phi D$	f	$\phi d$	l	$\phi F$	p	b	t
AW13	640	201	266	100	132	4-M16	42	37	80	4	12	3.5
AW17	827	270	348	160	190	8-M16	50	60	120	4	14	3.5
AW20	1162	350	425	200	232	8-M16	64	74	140	4	18	4
AW28	1380	460	527	280	318	8-M20	85	100	220	4	25	5
AW35 AW40	1860	545	440	300	350	8-M24	105	100	200	10	28x2	6.4

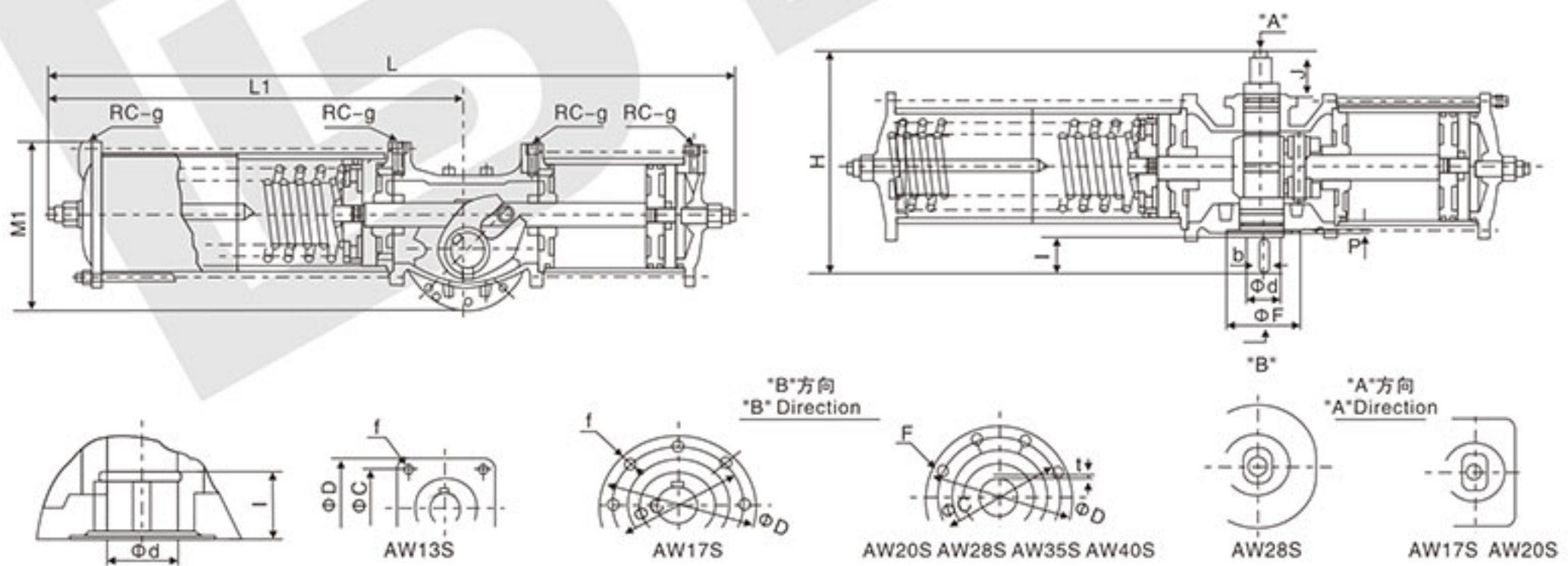

### 单作用式外形尺寸 Single Acting Shape Size

型号 Model	L	L1	M1	H	$\phi C$	$\phi D$	f	$\phi d$	l	$\phi F$	p	b	t	J	g
AW13S	858	538	201	266	100	132	4-M16	42	37	80	4	12	3.5	35	1/4"
AW17S	1090	675	270	348	160	190	8-M16	50	60	120	4	14	3.5	66	3/8"
AW20S	1430	850	350	425	200	232	8-M16	64	74	140	4	18	4	78	1/2"
AW28S	1845	1155	460	527	280	318	8-M20	85	100	220	4	28	5	84	1/2"
AW35S	2605	1670	545	440	300	350	8-M24	105	100	220	10	28x2	6.4	-	1/2"



AW气动执行器分解图 AW Series Decomposition Diagram

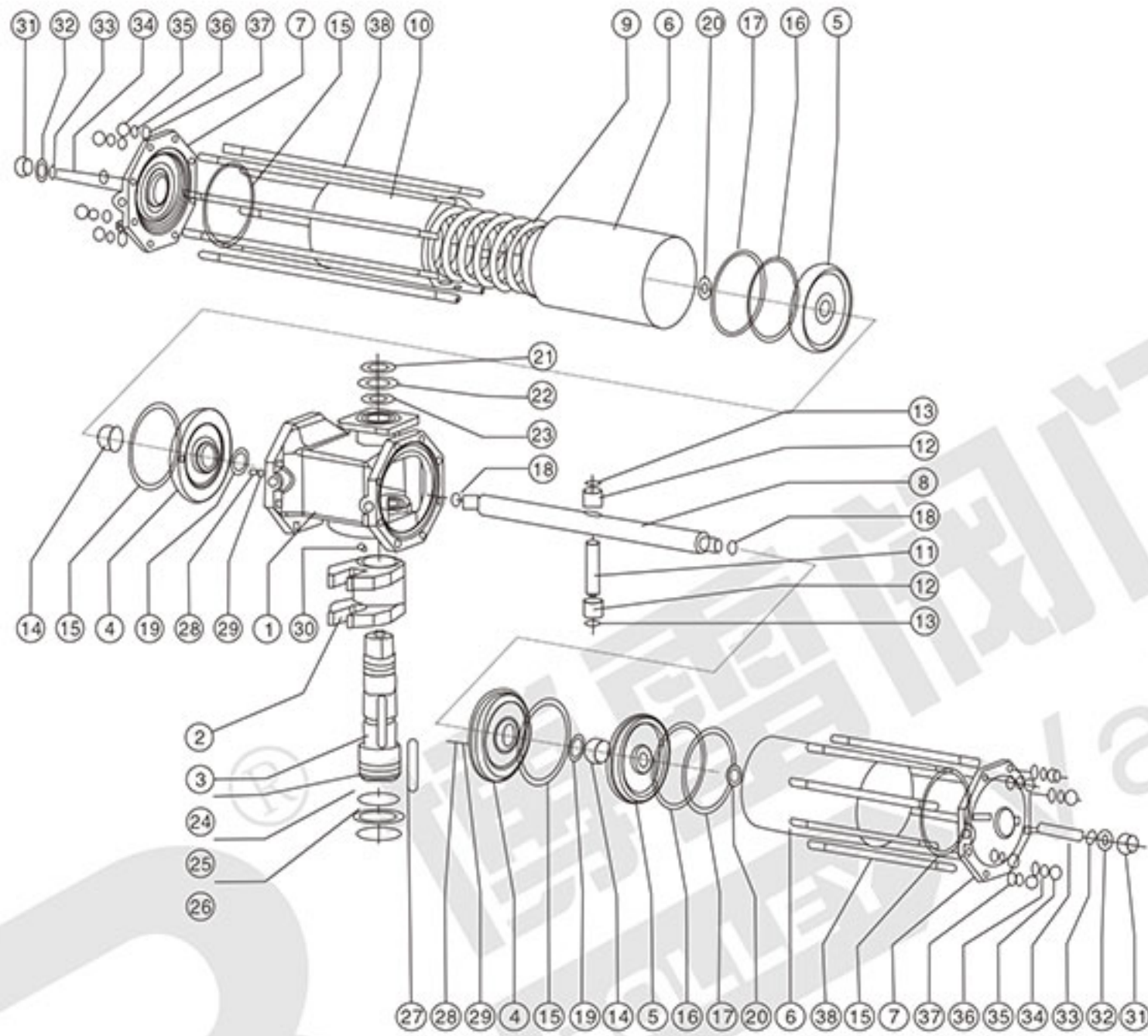

零件表 Parts List

序号 No.	名称 Name	数量 Quantity	序号 No.	名称 Name	数量 Quantity	序号 No.	名称 Name	数量 Quantity	序号 No.	名称 Name	数量 Quantity
1	箱体 Body	1	11	销轴 Pin	1	21	弹性挡圈 Flexible washer	1	31	锁紧螺母 Nut	2
2	拨叉 Shift Fork	1	12	滚套 Roller sets	2	22	减磨垫圈 Washer	1	32	平垫圈 Flat Pin	2
3	转轴 Axis	1	13	弹性挡圈 Flexible washer	2	23	O型圈 O-Ring	1	33	O型圈 O-Ring	2
4	隔板 Board	2	14	无油轴承 Oil Free Axle Bearing	2	25	O型圈 O-Ring	1	34	调节螺钉 Adjusted Screw	2
5	活塞 Piston	2	15	O型圈 O-Ring	2	25	减磨垫圈 Washer	1	35	螺母 Nut	8
6	缸体 Cylinder	2	16	导向环 Guide Ring	2	26	弹性挡圈 Flexible washer	1	36	弹性垫圈 Flexible washer	8
7	缸盖 Cylinder Cap	2	17	O型圈 O-Ring	2	27	平键 Flat Key	1	37	平垫圈 Flat Pin	8
8	活塞杆 Piston Rod	1	18	O型圈 O-Ring	2	28	O型圈 O-Ring	2	38	双头螺栓 Bolt	8
9	弹簧 Spring	1/2/4	19	O型圈 O-Ring	2	29	定位销 Locator Pin	2	39		
10	弹簧缸 Spring Cylinder	1	20	锁紧螺母 Nut	2	30	紧定螺钉 Screw	1	40		



# AW 系列气动执行器

## AW SERIES PNEUMATIC ACTUATORS

### AW系列带液压手动大规格气动执行器

#### AW Series Of Large-Sized Manual With A Hydraulic Actuator

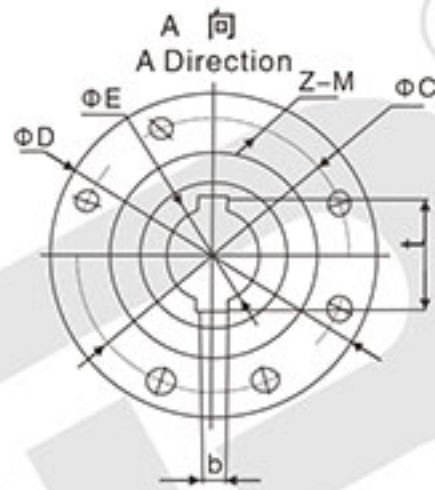
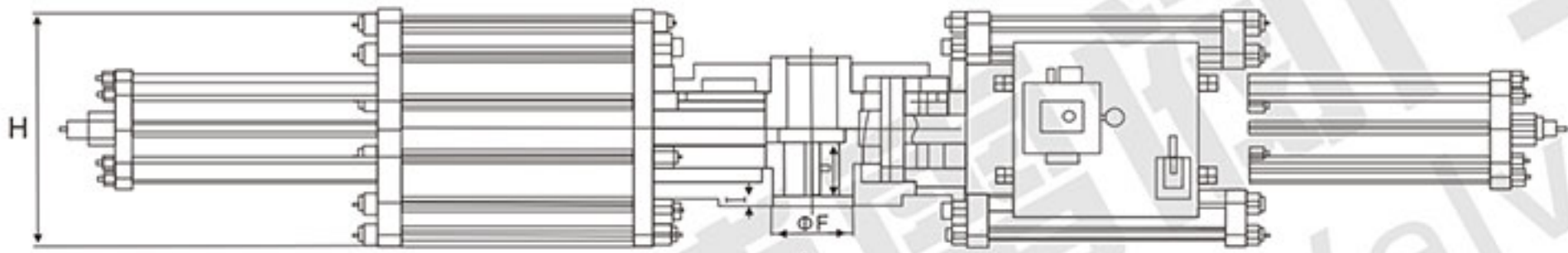
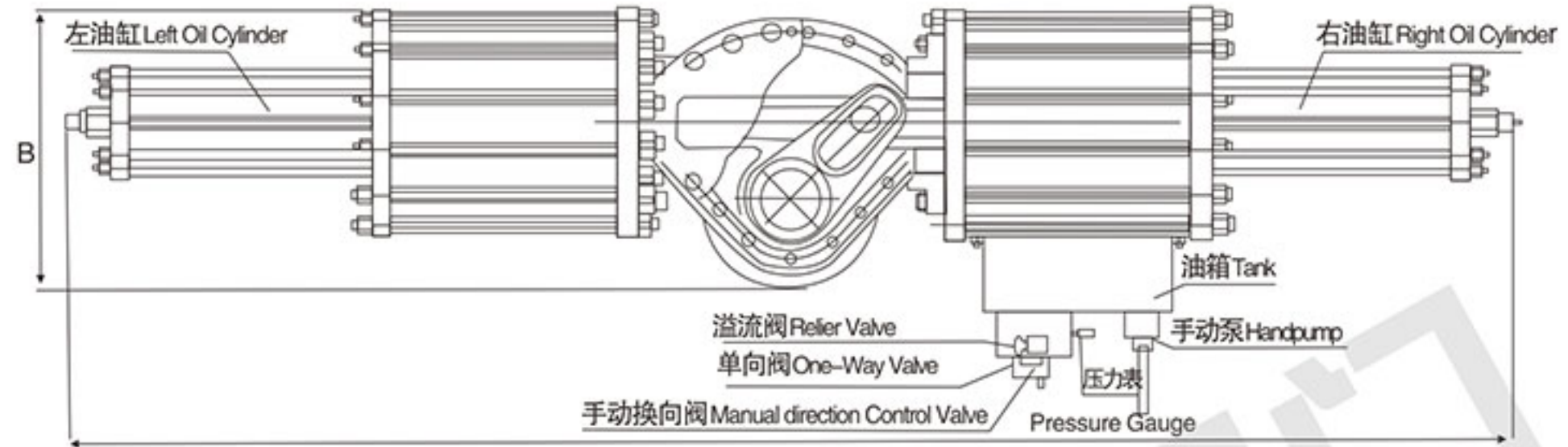

AW35SY AW40SY AW50SY AW60SY AW70SY

型号Model	L	B	H	ΦC	ΦD	ΦE	h	Z-M	ΦF	l	b	t
AW35SY	2842	545	444	300	350	105	110	8-M24	220	10	28	118
AW40SY	2842	570	490	300	350	105	110	8-M24	220	10	28	118
AW50SY	3355	675	590	350	400	120	170	12-M24	280	10	32	135
AW60SY	3952	820	720	450	500	160	192	12-M27	350	10	40	179
AW70SY	4406	938	815	480	560	180	220	12-M36	380	10	45	201

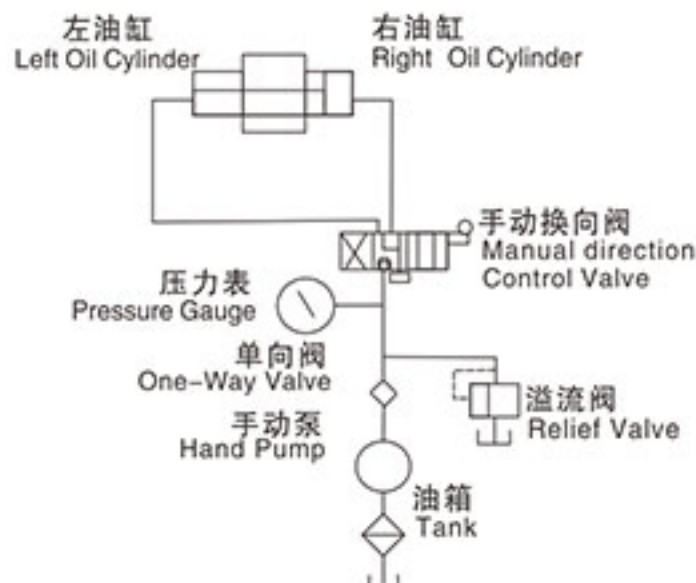

双作用液动原理图  
Double-acting hydraulic schematic

气动时，换向阀手柄在中位。手动时，调整好溢流阀。换向阀手柄向左关阀；手柄向右开阀，再按动手动泵即可。

Pneumatic, reversing valve handle in the median. Manual, adjust good relief valve. Reversing valve handle left closing valves ; The handle to the right open valve, Then press the manual pump can.



## ■ 产品的维护与保养 Product Maintenance & Maintenance

气动阀门执行器为现场仪表，应定期维护和保养，常年整洁、润滑良好、附件齐全，是气动阀门产品处于正常运转的保证。

气动执行器的日常维护工作：气源应保持干燥、清洁，定期对执行器相应配合使用的空气过滤器进行放水、排污，以免进入电磁阀和执行器，影响正常工作。执行器外表清洁，无粉尘污积；执行器应不受水蒸汽、水、油污的沾染。气动执行器的密封应良好，各密封面、点应完整牢固，严密无损。气缸进出口接头不允许有损伤；气缸和空气管系的各部位应进行仔细检查，保持气源压力正常。管子不允许有凹陷，保持畅通，不得有影响使用性能的泄漏。不论是电磁阀、气源处理三联件、定位器的气源管路连接应完好无损，不得有任何泄漏。电气部分的电源信号或调节电流信号应无缺相、短路、断路故障，外壳防护接头连接应紧实、严密，防止进水、受潮与灰尘的侵蚀，保证电磁阀的正常工作。信号回信器应处于完好状态，以保证阀门开关位置的信号传送，手动操作机构应润滑良好，启闭灵活。

气动执行器上的阀门外部表面应保持清洁，经常去除灰尘、油污以及介质残渍等等脏物。对于阀门的活动部位必须保持清洁，以免产生磨损和腐蚀。在运行中阀门应完好、无泄漏，开启和关闭灵活。各种零件应齐全、完好。法兰和支架上螺栓不可缺少，螺母应完好无损，不允许有松动现象，发现松动应及时拧紧，以免磨损连接造成开启和关闭的位置不正确，产生泄漏。填料压盖不允许歪斜，避免对阀杆部位摩擦而咬死造成执行器不灵或不能正常工作。

因此对气动阀门维护与保养十分重要，才能达到整个气动仪表控制系统处于正常工作状态。在正常工作情况下每月检验不少于一次，每年检修一次。

Pneumatic valve sets the scene for the instruments, and should be subject to periodic maintenance and repair. Perennial clean, good lubrication, annex complete, is pneumatic valve products in the normal operation of the guarantee.

Pneumatic Actuators the daily maintenance, gas source should remain dry, clean, on a regular basis with the corresponding actuator with the use of air filters for water distribution, sewage, to avoid entering the solenoid valve and actuator, affect normal work. Actuator appearance clean, no dust pollution plot; Actuator should be excluded from the steam, water, oil contamination. Pneumatic Actuators be good seal, the sealing surface, the points should be solid integrity, tight nondestructive, Import and export gas cylinder connector does not allow any injury; Cylinder and air pipe system in the are should be carefully examined. Maintain normal air pressure. Pipe is allowed to sag, unimpeded, shall not affect the performance of leakage. Whether electromagnetic valve, gas processing triple pieces locate sources of natural gas pipeline linking should be intact, not a leak, Part of the electrical power supply signals or adjust the current signal should be no shortage phase, short circuit, open circuit failure, protective casing. joints connecting it to be tight, tight to prevent the inlet, moisturizing and dust erosion, and ensure the solenoid valve locator or normal work. Signal devices should reply in good condition to ensure the valve position signal transmission. manual operation should be good lubrication, Hoist flexible

Pneumatic actuator valve on the external surface should be kept clean and often remove dust, oil and other medium residual dirt stains. Valve activities for the site must be kept clean and to avoid wear and corrosion. In the operation of the valve should be intact, not leaking, open and closed flexible. All valves should be complete, intact. And the flange bolts on the stent indispensable thread should intact, and not allowed to have loosened. If found to be loose in a timely manner tightening to avoid causing wear connect open and closed position is not correct, leakage, Packing gland allowed askew to avoid friction and stem were killed, causing problems for the implementation of the normal work or not.

So right pneumatic valve maintenance and maintenance is very important in order to achieve the entire pneumatic instrument control system is in normal working condition, In normal working conditions, not under examination at least once a month, an annual overhaul.



### 一般的问题解决指南 General Solutions Guide

故障现象 Problems	检查项目 Items	解决方法 Solutions
气动阀门不能动作 Pneumatic valve doesn't work	(1) 电磁阀是否正常、线圈是否烧坏、电磁阀芯是否被脏物卡死。 (1) Solenoid valve doesn't work or coil burnt, magnetic spool jammed by dirt	(1) 更换电磁阀、更换线圈、清除脏物。 (1) Replace solenoid valve or coil; Remove dirt.
	(2) 对执行器单独供气检验, 是否正常工作, 如气缸串气不正常, 拆开执行器检查封件是否已损坏, 气缸内孔表面是否已损坏。 (2) For the implementation of separate gas test, normal work, such as gas cylinder series is not normal work, unpick actuator check whether the seals damaged cylinder hole to the surface whether damage.	(2) 更换已坏密封圈, 更换气缸。 (2) Replacing the bad gasket replacement cylinder.
	(3) 阀内有杂质将芯卡住。 (3) Valve comes with impurities-cab.	(3) 清除杂质更换已损阀件 (3) Clear impurities replacing damaged Annex.
	(4) 手动操作机构的手柄处在手动位置。 (4) the handle of Manual operation at the manual position.	(4) 将手柄扳到气动位置。 (4) To the handle of pneumatic wrenches location.
气动阀门动作迟缓、爬行 Pneumatic valve moves slowly, crawling	(1) 气源压力不够。 (1) Air source pressure not Enough.	(1) 增加气源压力 (一般试验 < 0.4Mpa, 使用时 0.4~0.7Mpa) (1) Increase air source pressure (general test 0.4Mpa; work 0.4~0.7Mpa).
	(2) 气动执行器扭矩过小。 (2) Pneumatic actuator torque too small.	(2) 增大执行器型号规格。 (2) Increase actuator model specifications,
	(3) 阀门阀芯或其它阀件装配太紧不合理。 (3) Valve spool valve or other inappropriate component assembly corner.	(3) 重新修理装配, 调整阀门扭矩。 (3) Re-assembly repairs, adjusting valve torque.
	(4) 气源管路堵塞流量过小。 (4) Gas pipeline is too small to plug the flow.	(4) 排除堵塞。 (4) Exclude plug.
回信器无信号 Reply with no signal	(1) 信号电源线路: 短路、断路。 (1) Signal power lines, short circuit, open circuit.	(1) 维修电源线路。 (1) Power line repair.
	(2) 凸轮位置不准确。 (2) Cam location inaccurate	(2) 重新调整凸轮到正确位置。 (2) Cam re-adjusted to the correct location.
	(3) 微动开关损坏。 (3) Micro switch damaged	(3) 更换微动开关。 (3) Replace micro switch





**天津市博雷阀门有限公司**  
TIANJIN BOLLEY VALVE CO. LTD.

地址(Add): 天津市南开区密云一支路

电话(Tel): 022-27575088

传真(Fax): 022-87880319

Http: //www.bl-bolley.com

E-mail: cn@bolley.cn